



WARNING

With improper application, there is a disclaimer.

Clean filter after 4 hours → remove it → beat it or wash it, let it dry afterwards



Operating manual



Granulate choice

Never fill the container with granules completely! Bracing the container tightly with the appropriate metal brackets. When not using the blasting media, it must be removed from the blasting container.



Keep blasting media always closed and dry.

For the change of blasting media, the entire system must be cleaned from all granules used so far, or you may cause damage to sensitive surfaces. The cleaning affects all suction hoses, jet cap and lance as well as the container and metering device..



cleaning Tornado ACS

Advice: After the suction is finished – tilt up jet hood first so that the abrasive residue can be collected and removed by suction.

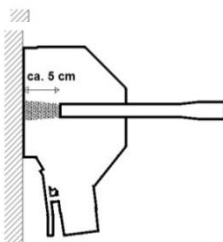

Distance surface – Jet lance



The fields of applications are very diverse.

The Tornado ACS cleaning equipment removes persistent and problematic pollutants on various surfaces, like **brick, concrete, plaster, natural stone, tile, wood, plastic and metal.**

Any solid pollutant can be removed, such as:
graffiti, rust, limestone and paint.

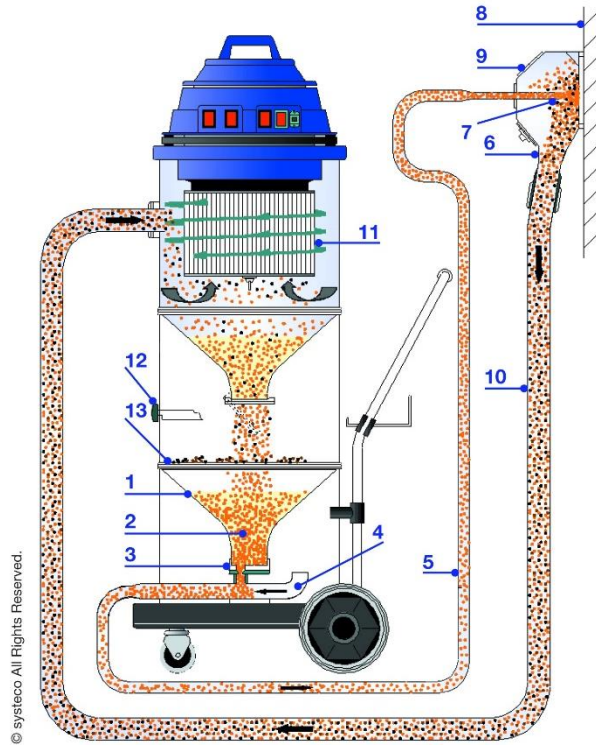

© systemco All Rights Reserved.

1. put in plug
2. switch on lighting
3. switch on motors (one by one)
4. fill or suck in blast media, turn off
5. use flap (12), granulate is fed to the circuit, switch on
6. place jet hood (6) onto surface (8) Jet hood adheres to it.
7. insert jet lance (7) in jet hood (6)
8. blasting process begins. From a funnel (1) the blasting material (2) reaches the airflow (4) through the metering device (3) by gravity. With a flexible suction hose (5) blasting material is transported to jet cap (6) and accelerates to a speed of 400 km/h –at exit of jet lance (7). Blast material hits the polluted surface (8) and loosens the grime.
9. steady movement of jet lance, watch and control blasting process through 3 vision panels (9)
10. blast material mixture is sucked off by the hose (10) into top of blast material container. Fine dust is sucked in by a dry vacuum into a fine dust filter (11) and coarse particles are kept back by a strainer (13).
11. Vacuum blast entire surface
12. Operate airflap on jet cap, loosen cap – blasting process is automatically interrupted, displace jet hood
13. If entire blast media is in middle container, loosen flap (12) until blast media is inside dosing tank, lock flap
ATTENTION turn off vacuum first.
14. After finish work, place down jet hood and jet lance, switch off motor and lighting.